

# CAV

## DISTRIBUTOR TYPE FUEL INJECTION PUMPS TYPE DPA

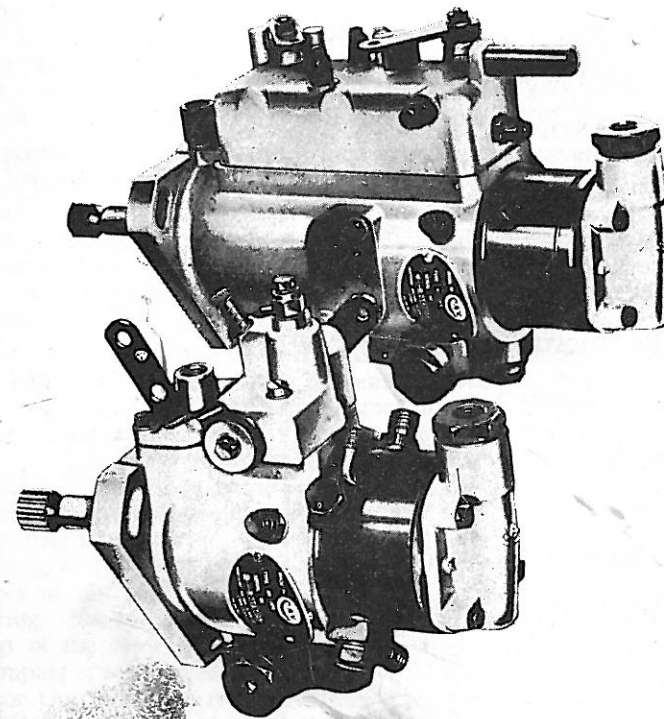

**INSTRUCTION BOOK**

---

# CAV

ACTON, LONDON, W.3

Telephone: 01-743 3111

Telegrams: VANTERIA TELEX LONDON

## CONTENTS

	<i>Page</i>
DESCRIPTION .. .. .	3
Metering of fuel .. .. .	5
Pumping and distribution .. .. .	5
End plate and regulating valve .. .. .	7
Maximum fuel adjustment .. .. .	8
Governing .. .. .	8
Typeplate .. .. .	8
FUEL SYSTEMS .. .. .	8
FITTING AND TIMING THE PUMP TO AN ENGINE .. .. .	11
PRIMING AND STARTING .. .. .	12
Priming .. .. .	13
Starting procedure .. .. .	13
Failure to start .. .. .	14
FAULT RECTIFICATION .. .. .	14
Faulty injectors .. .. .	14
Leaking injection pipe unions .. .. .	14
Clogged filter .. .. .	14
Air in the pump .. .. .	14
Water in fuel .. .. .	15
MAINTENANCE .. .. .	15
INHIBITING .. .. .	15

# CAV

## DPA TYPE DISTRIBUTOR PUMP

### DESCRIPTION

**I**N the C.A.V. distributor type injection pump the fuel is pumped by a single element, and the fuel charges distributed in the correct firing order and at the required timing interval to each cylinder in turn by means of a rotary distributor, integral with the pump. In consequence, equality of delivery to each injector is an inherent feature of the pump and deliveries are not subject to maladjustment.

Similarly, since the timing interval between injection strokes is determined by the accurate spacing of distribution ports and high precision operating cams that are not subject to adjustment, accurate phasing is also an inherent feature.

The pump is a compact, oil-tight unit, lubricated throughout by fuel oil and requires no separate lubrication system. It contains no ball or roller bearings, gears, or highly stressed springs, and the number of parts and overall size of the pump remain the same irrespective of the number of engine cylinders it is required to serve.

Sensitive speed control is maintained by a governor, either mechanically or hydraulically operated, embodied in the pump.

Variation of injection timing, which is required on some applications, can be obtained on models of the pump fitted with an advance device. Except where a manually operated start retard is incorporated, the advance device is fully automatic and requires no attention from the operator.

The main features can be seen in the cut-away illustrations (see pages 4 and 6). First, note that there is a central rotating steel member known as the pumping and distributing rotor; this is driven by splines from a drive shaft and carries at its outer end a vane type fuel transfer pump. The rotor is a close fit in a stationary steel cylindrical body, called the hydraulic head. The pumping section of the rotor has a transverse bore containing two opposed pump plungers. These rotate inside a cam ring in the pump housing, and operate through rollers and shoes sliding in the rotor. Normally the cam ring has as many internal lobes as the engine has cylinders. The opposed plungers have no springs, but are moved outwards by fuel pressure. The distributing part of the rotor contains a central axial passage that connects the pumping space between the plungers with ports drilled radially in the rotor. One radial hole is the distributing port, and as the rotor turns this aligns successively with a number of outlet ports (equal to the number of engine cylinders) in the hydraulic head, from which the injectors are fed via external high pressure pipes. A similar number of inlet ports in the rotor align successively with a single port in the head. This is the inlet or metering port, and admits fuel under the control of the governor.

1. Governor Weights
2. Drive Hub Securing Screw
3. Quill Shaft
4. Drive Hub
5. Back Leak Connection
6. Shut-Off Lever
7. Governor Spring
8. Idling Stop
9. Control Lever
10. Maximum Speed Stop
11. Metering Valve
12. Fuel Inlet
13. End Plate Assembly
14. Hydraulic Head
15. Rotor
16. Nylon Filter
17. Regulating Valve Sleeve
18. Regulating Piston
19. Priming Spring
20. Transfer Pump
21. To Injector
22. Advance Device
23. Cam Ring
24. Plungers

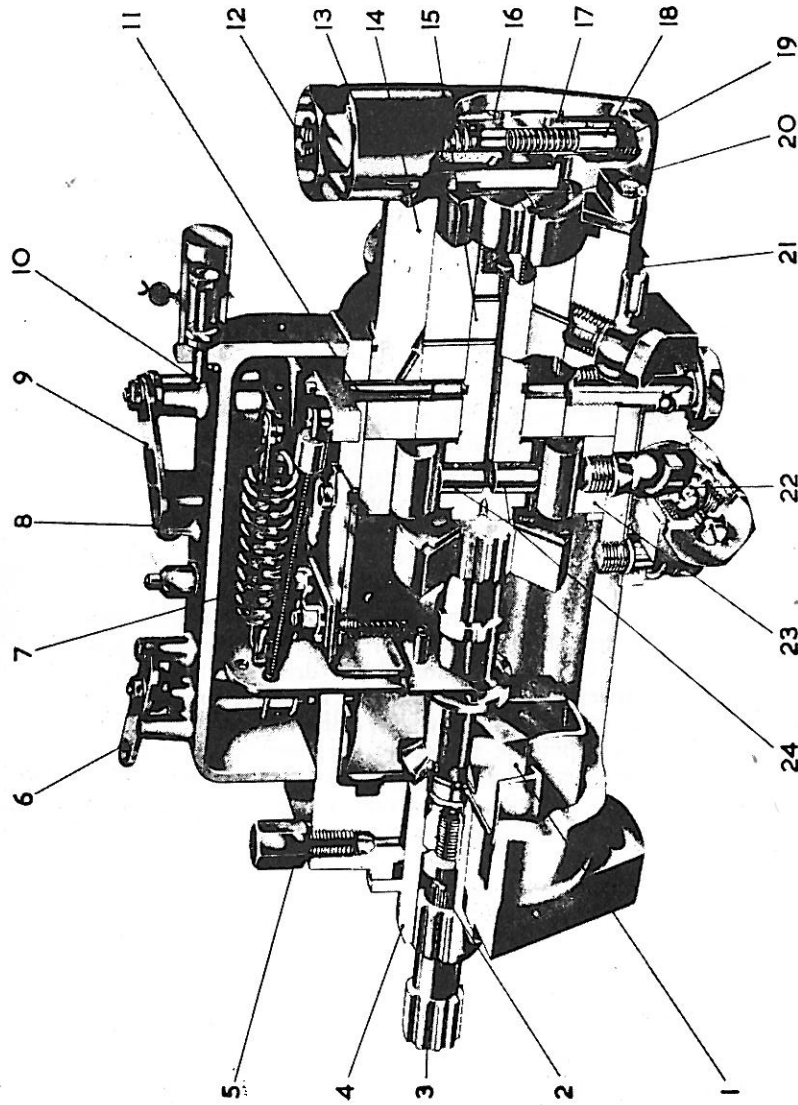

Fig. 1. Pump with mechanical governor and automatic advance device

### Metering of fuel

Fuel entering the pump through the inlet connection on the pump end plate, passes through a fine gauze filter to the inlet side of the vane type transfer pump.

The fuel pressure is then raised to an intermediate level, known as transfer pressure, and is controlled by a piston type regulating valve housed in the end plate. Transfer pressure does not remain constant but increases with the speed of rotation of the pump. Fuel at transfer pressure then passes through a passage in the hydraulic head to an annular groove in the rotor and thence to a chamber which houses the metering valve. The metering valve is operated by the control lever and regulates the flow of fuel through the metering port into the pumping section of the rotor. The volume of fuel passing into the pumping element is thus controlled by the transfer pressure, the position of the metering valve, and the time during which an inlet port in the rotor is aligned with the metering port in the hydraulic head.

### Pumping and distribution

The functions of pumping and distribution of the metered fuel are illustrated in Fig. 2. The left-hand diagram shows the charging phase and the right-hand diagram the actual pumping and distribution of the metered charge.

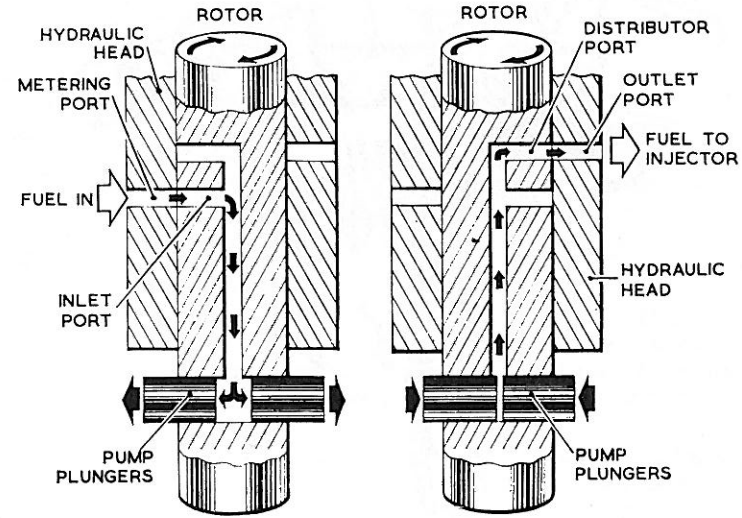

Fig. 2

1. Plungers
2. Drive Shaft
3. Back Leak Connection
4. Control Lever
5. Idling Stop
6. Vent Screw
7. Governor Spring
8. Metering Valve
9. Hydraulic Head
10. Fuel Inlet
11. End Plate Assembly
12. Rotor
13. Nylon Filter
14. Transfer Pump
15. Regulating Valve Sleeve
16. Regulating Piston
17. Priming Spring
18. To Injector
19. Advance Device
20. Cam Spring

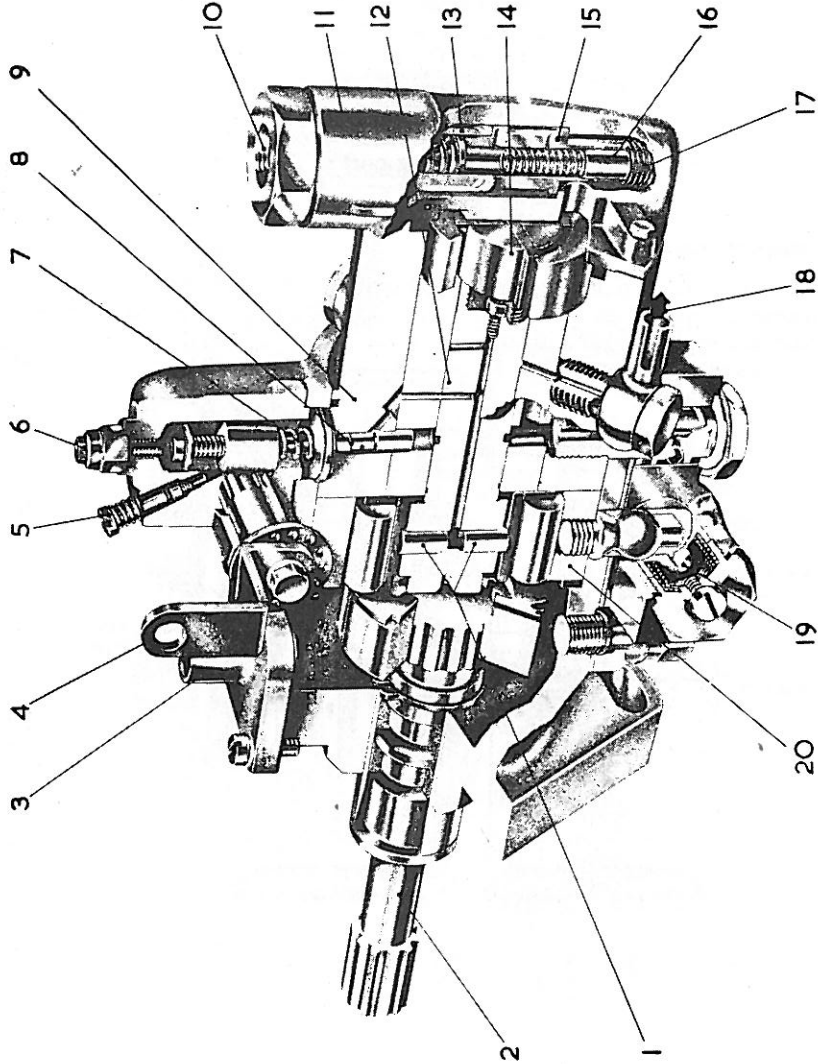

Fig. 3. Pump with hydraulic governor and automatic advance device

As the rotor turns, a charging port in the rotor is aligned with the metering port in the hydraulic head and fuel at metered pressure flows into the central passage in the rotor and forces the plungers apart. The amount of plunger displacement is determined by the amount of fuel which can flow into the element while the ports are aligned. See left-hand diagram.

The inlet port closes as rotation continues, and as the single distributor port in the rotor comes into alignment with one of the distributor ports in the hydraulic head, the actuating rollers contact the cam ring lobes, and the plungers are forced inwards as shown in the right-hand diagram. High pressure is generated and fuel passes to the injector.

### End plate and regulating valve

The end plate houses the regulating valve assembly and a fine mesh nylon filter. The fuel inlet connection which locates and secures this assembly is mounted externally.

The regulating valve performs two separate functions. Firstly, it controls transfer pressure, maintaining a predetermined relationship between the pressure and the speed of rotation. Secondly, it provides means of by-passing the vanes of the transfer pump when the pump is stationary, so that the fuel passages in the hydraulic head can be primed.

Fuel entering the end plate at feed pressure passes to the inlet side of the transfer pump through the nylon filter and the upper fuel passage. Transfer pressure is transmitted to the underside of the regulating piston through the lower fuel passage and tends to force the piston upwards. This force is opposed by pressure exerted on the upper face of the piston by the regulating spring.

As transfer pressure rises with increasing engine speed the piston is forced upwards and the regulating spring is compressed. Such movement of the piston progressively uncovers the regulating port and regulates transfer pressure by permitting a metered flow of fuel back to the inlet side of the transfer pump. The effective area of the regulating port is increased as engine speed is raised, and is reduced as engine speed falls. On certain pumps, the maximum movement of the piston is restricted by a screw in order to increase the rate at which transfer pressure rises. The screw, which is referred to as a transfer pressure adjuster, is set during manufacture to suit the application concerned.

When priming a pump, fuel entering the end plate cannot pass through the transfer pump and into the fuel passages in the hydraulic head in the normal way. Fuel at priming pressure enters the valve sleeve and acts on the upper face of the regulating piston. The piston is forced to the lower end of the valve sleeve, compressing the priming

spring and uncovering the priming ports. Fuel then passes through the priming ports and the lower fuel passage to the outlet side of the transfer pump, and thence into the fuel passages within the hydraulic head.

End plates of recent manufacture are made of aluminium. End plates of earlier manufacture are made of steel and contain a similar regulating valve which is located on a centre line at right angles to that of the fuel inlet connection. Functionally, the valves in both end plates are identical.

### Maximum fuel adjustment

Since the amount of outward displacement of the plungers is governed by the amount of fuel permitted to enter the element, a maximum fuel setting can be made by limiting the maximum outward movement of the plungers. This setting is made after manufacture or overhaul and must not be altered by the operator.

### Governing

Two types of governor are used on DFA pumps, a mechanical governor operated by changes in centrifugal force acting on a number of flyweights, and a hydraulic type, operated by changes in transfer pressure acting directly on the metering valve. Both types of governor are effective throughout the speed range of the engine and ensure that steady governed speeds are maintained from idling to maximum engine r.p.m.

### Typeplate

The number stamped on the typeplate attached to the pump housing identifies the type and model of the pump. Pumps that are of identical build, but set differently to suit different applications are further identified by the setting code stamped beneath the ordering number.

**Note**—Should the typeplate be obscured by paint, care must be taken to ensure that the type details are not defaced when removing the paint.

## FUEL SYSTEMS

Typical fuel systems incorporating all the required features are illustrated in Figs. 4 and 5. Fuel oil may be fed to the injection pump by a lift pump, or by gravity feed; in the latter case there must be a head of fuel of more than 1 ft.

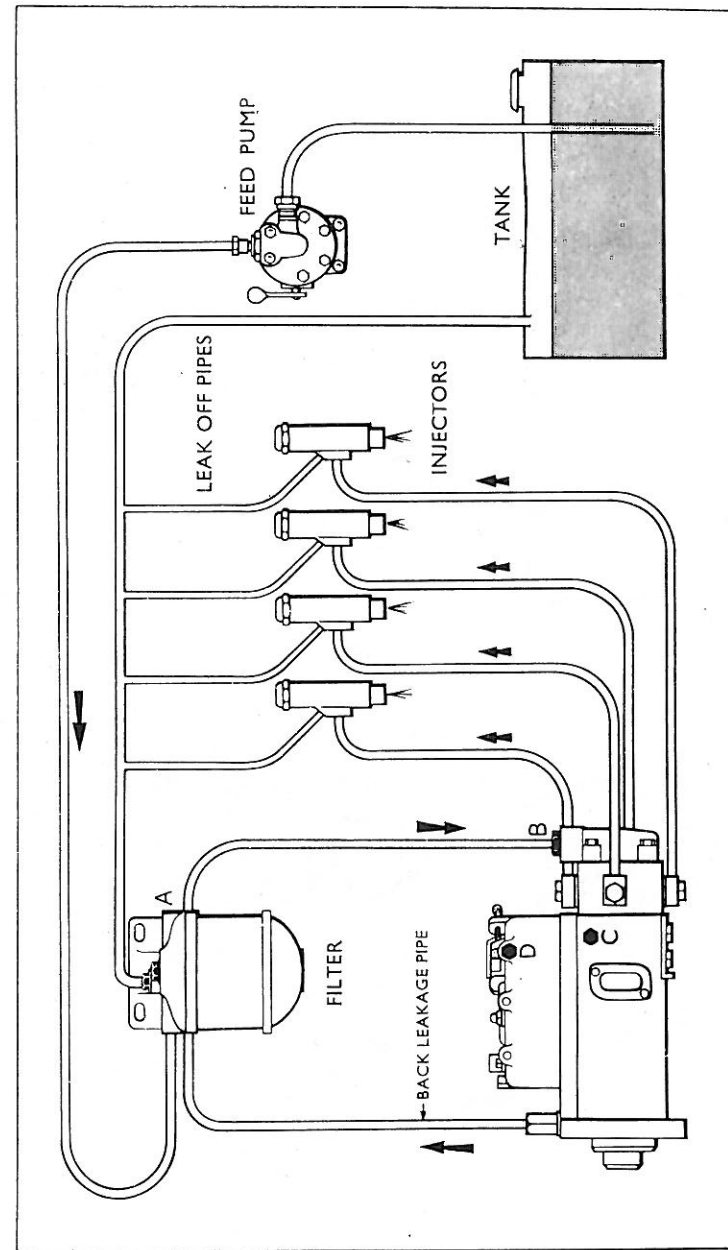

Fig. 4. Typical fuel system with lift pump

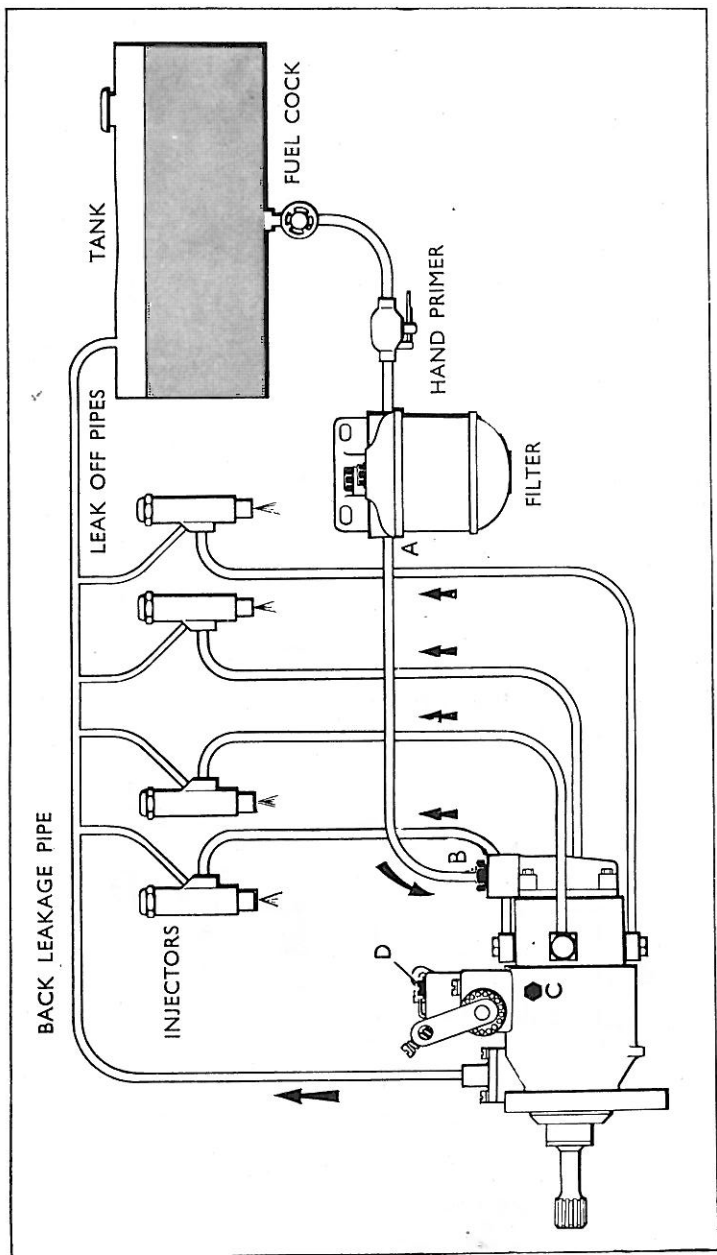

Fig. 5. Typical fuel system with gravity feed

Since a large proportion of injection pump failures can be directly attributed to wear and damage caused by small particles of abrasive matter which have penetrated into the fine clearances between working parts, it will be appreciated that the efficient filtration of the fuel oil is of utmost importance.

It is essential that the C.A.V. paper element filter is fitted. This is the ideal filter unit, providing the necessary degree of filtration and requiring the minimum of attention; periodic replacement of the "throw away" type paper filter element is all that is required to maintain its high standard of efficiency. Filter element life will necessarily vary according to the operating conditions, the quality and cleanliness of the fuel and with the capacity of the engine, and operators are advised to service these filters in accordance with the vehicle or engine manufacturer's instructions. Only genuine C.A.V. paper elements should be used, as substitutes do not give the same protection and can lead to excessive pump wear.

Every precaution should be taken to prevent the ingress of dirt and water into bulk storage tanks, which should be tilted to provide a sump into which all suspended impurities can settle. "Draw off" taps should be fitted at the end of the tank remote from the sump. Accumulated sludge must be drained off at regular intervals to ensure that it never reaches the level of the "draw off" tap.

#### FITTING AND TIMING THE PUMP TO AN ENGINE

Both hydraulically and mechanically governed pumps are driven by a splined shaft provided with a master spline. The master spline is engaged with a corresponding master spline on the engine during fitment, and ensures correct location for pump timing.

On mechanically governed pumps the splined shaft is referred to as a quill shaft and is detachable, but on some applications, the quill shaft is replaced by a special keyed drive hub that bolts on to the engine coupling—some early models of mechanically governed pumps have a quill shaft with a small locking screw at one end. It is important that this screw is engaged in the socket head of the drive hub securing screw before tightening the pump to the engine.

On certain hydraulically governed pumps, a torsion bar is fitted to iron-out back-lash in the drive shaft. The device consists of a flat bar engaged between the end of the rotor and the pump drive coupling on the engine. The bar runs through the centre of the drive shaft and is made to twist during engagement of the pump to the engine.

Since the procedure for timing and fitting is not standard for all engines, reference must be made to the engine manufacturer's handbook before carrying out this work. In an emergency however, and if the timing marks are clearly marked on the engine and the pump mounting flange, most pumps can be fitted as follows:—

1. Turn the pump drive shaft so that the master spline is in alignment with the master spline on the engine coupling.
2. Enter the drive shaft into the engine coupling as the pump is pushed on to the securing studs.
3. Push the pump hard against the mounting face and secure lightly with the three holding nuts.
4. Rotate the pump on the retaining studs until the timing mark scribed on the edge of the pump mounting flange is accurately aligned with the timing mark on the engine.
5. Tighten the retaining nuts.
6. Connect and tighten the back-leakage pipe.
7. Connect and tighten the fuel pipe to the inlet connection on the pump end plate.
8. Connect the "shut off" lever on the pump to the control linkage and ensure that the lever has a full range of movement when the control is operated.
9. Connect the throttle lever on the pump with the throttle control linkage, and ensure that the lever has a full range of movement when the control is operated. When on a vehicle, **set the control stops so that pressure on the accelerator pedal is not transmitted to the maximum speed stop on the pump.** Setting instructions should be contained in the manufacturer's handbook.

**Note**—No attempt must be made to start the engine until the pump has been filled and primed in accordance with the following instructions.

When a pump has been timed by the "emergency" method, an early opportunity should be taken of checking the setting by the manufacturer's instructions.

## PRIMING AND STARTING

The following priming sequence is applicable to the typical fuel systems shown in Figs. 4 and 5. When a particular fuel system varies from that shown in the illustrations refer to the vehicle manufacturer's handbook.

## Priming

Priming is necessary on initial installation of the fuel injection system, after any subsequent removal, and if the system should be drained by running out of fuel.

Before priming and venting, ensure that the outside of the vent screws and surrounding area is thoroughly clean to prevent dirt and foreign matter entering the system.

Carry out operations 1 and 2 whilst operating the fuel system priming lever.

1. Slacken the filter outlet (A), or the fuel pump inlet connection (B) whichever is the higher, and allow fuel to flow until free of air. Tighten connections.

**Note**—Filters of the four boss type must also be vented at the plugged boss; this must be done irrespective of the height of the filter in the system.

2. Slacken the vent valve fitted on one of the two hydraulic head locking screws (C), and the vent screw (D) on the governor housing. When fuel free from air flows from the vents, tighten the housing vent screw and then the governor vent screw.
3. Slacken any two injector high pressure pipe unions at the injector end. Set the accelerator to the fully open position and ensure that the stop control is in the "run" position. Turn the engine until fuel free from air flows. Tighten unions.
4. Start engine.

For priming procedure after changing a filter element, carry out the operations detailed in paragraph 1 above.

## Starting procedure

Where special starting aids are provided, refer to the vehicle manufacturer's handbook, otherwise proceed as follows:—

1. Ensure that the "shut off" control is in the "RUN" position.
2. Set the engine control in the full throttle position.
3. Press the starter button, and when the engine is firing evenly return the throttle control to the idling position when the governor will take over control.
4. Where a manually operated start retard device has been used, it must be released after starting, otherwise the pump will be retarded throughout the speed range of the engine.

**Note**—If a new or reconditioned pump has been fitted the idling stop must be adjusted and the maximum governed speed set according to the engine manufacturer's instructions.

## Failure to start

Starting difficulties are not always attributable to faulty fuel injection equipment and may result from poor compression caused by cylinder wear, "gummed up" rings, sticking or badly seated valves, or from insufficient tappet clearance. When no starting aid is fitted, difficulty may be experienced when starting in extremely cold weather.

1. Ensure that there is fuel in the tank and that the fuel cock is turned on. If the tank has run dry, the pump must be filled and primed in accordance with the instructions on page 12, after the tank has been refilled.
2. Check the position of the "shut off" control.
3. Inspect for oil leaks at the injector pipe connections and tighten as necessary.
4. Fill and prime the pump to remove all air from the system. See page 12.
5. Inspect the filter element and replace if clogged. Prime the system after reassembling the filter. See page 12.
6. Remove each injector in turn and after reconnecting the high pressure injector pipe with the nozzle directed away from the engine, turn the engine and ensure that fuel passed through the injector is correctly sprayed and atomised. Replace any faulty injectors.

## FAULT RECTIFICATION

Possible causes of rough running, together with appropriate remedies are listed below.

### 1. Faulty injectors

Remove each injector in turn, reconnect the high pressure pipe with the injector nozzle pointing away from the engine, and while turning the engine ensure that fuel passing through the injector is correctly sprayed and atomised. Replace faulty injectors.

### 2. Leaking injection pipe unions

Inspect all unions for signs of oil leakage and tighten as necessary.

### 3. Clogged filter

Remove and replace the paper filter element, and prime in accordance with instructions on page 12.

### 4. Air in the pump

Slacken each injector pipe coupling in turn (at the injector end) while the engine is running, and re-tighten when oil, free from air bubbles, leaks past the union threads. If engine running does not improve, fill and prime the pump in accordance with the instructions on page 12.

## 5. Water in fuel

When the presence of water in the fuel is suspected, the filter bowl should be drained daily until the amount of water so removed indicates that less frequent draining will be adequate to prevent water from entering the fuel injection pump. If more than a teacupful of water is drained off, the source of ingress must be found or else the filter bowl must be drained at more frequent intervals.

If rough running persists after the above tests have been made, the advice of the nearest C.A.V. agent should be sought.

## MAINTENANCE

Apart from periodic replacement of the filter element and servicing of injector nozzles, a fuel system incorporating a DPA type fuel injection pump requires no maintenance. If the necessary care is given to the cleanliness of fuel, both in the fuel system and the bulk storage installation, the pump will give many thousands of hours of trouble-free service.

## INHIBITING

When the vehicle is to remain idle for long periods as, for example, while in storage or in transit overseas, the pump and fuel injection system must be protected from corrosion in the following manner.

Each particular installation must be dealt with as the fuel layout demands. In general, the principle to be observed is that existing fuel should be drained as far as possible from the tank, the filter and pipework, and the injectors. The whole system must then be refilled with a non-corrosive fuel, the pump filled and primed, and the engine then run for a period sufficient to ensure that the whole system has been inhibited. Detailed instructions for any vehicle, tractor or installation should be given in the manufacturer's handbooks, and should be followed closely.

Further information and literature on inhibiting and storage of fuel oils, is available from all C.A.V. agents and depots.